

7

# Boundaries and Choices

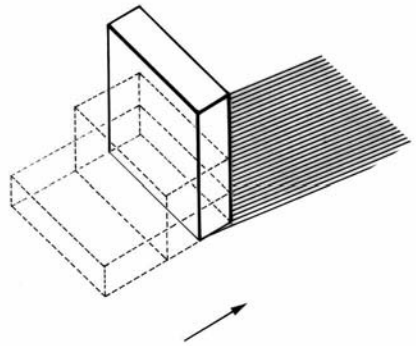

**T**HUS FAR WE HAVE LOOKED AT THE TIME-HONORED WAYS people have identified with the rhythms of nature through ritual acts of sheltering—celebrations of life in a place. But how do they relate to a place of extraordinary growth? What are the rhythms and rituals that foster enjoyment in great cities, that call up possibilities for individual choice and self-expression? Consider life in Greater Los Angeles, a metropolitan region of 3500 square miles (9065 sq km) that has begun to hit limits of space and time. Development has reached the geographical constraints of mountain, ocean, and desert. People are also becoming dissatisfied with the increasing time they must spend on the daily commute. Such limits are already leading to the rebuilding at higher densities of some older parts of Los Angeles as well as other sprawling U.S. cities. The question is how to direct that denser growth to better connect us to nature for energy, comfort, and choice.

While the scale of modern growth has clearly changed, long-established modes of sheltering can offer a useful model for today. First, those modes were sustainable since they depended on building designs and patterns of life to provide comfort, not on energy-intensive mechanical and electrical systems. Second, they offered time-rich environments that called forth ritual modes of self-expression, not impassive responses to experiential monotones. Finally, they linked people to places, to the land and climate. To regain these advantages while providing for growth, we need to explore new urban planning policies that expand choices for designer and dweller alike.

## Greater Los Angeles

Los Angeles is a story of water and cars. Water made growth possible in the semidesert of Southern California. The Owens Valley